

5.8CY-14S-24I-TUB-CAB-SGT-SD

NOTES:

- 1. 3/16 MAINRAILS
- 2. FLOOR SHEETS AND POSTS ARE 7GA
- 3. WALLS, FRONT, AND DOOR IS 12GA
- 4. TOPRAILS ARE 11GA X 3 X 4, FLIPPED
- 5. SEALED GATE

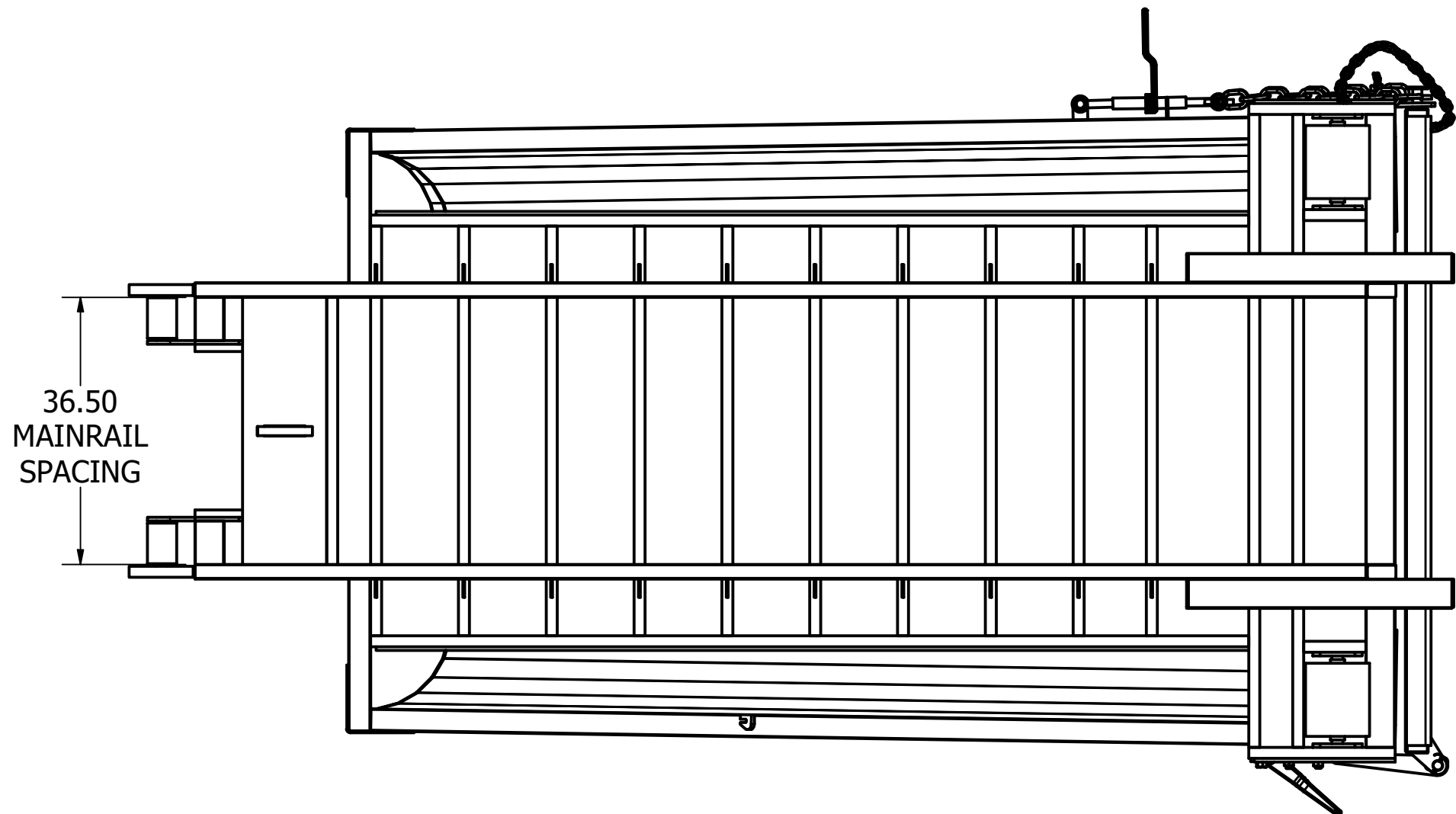
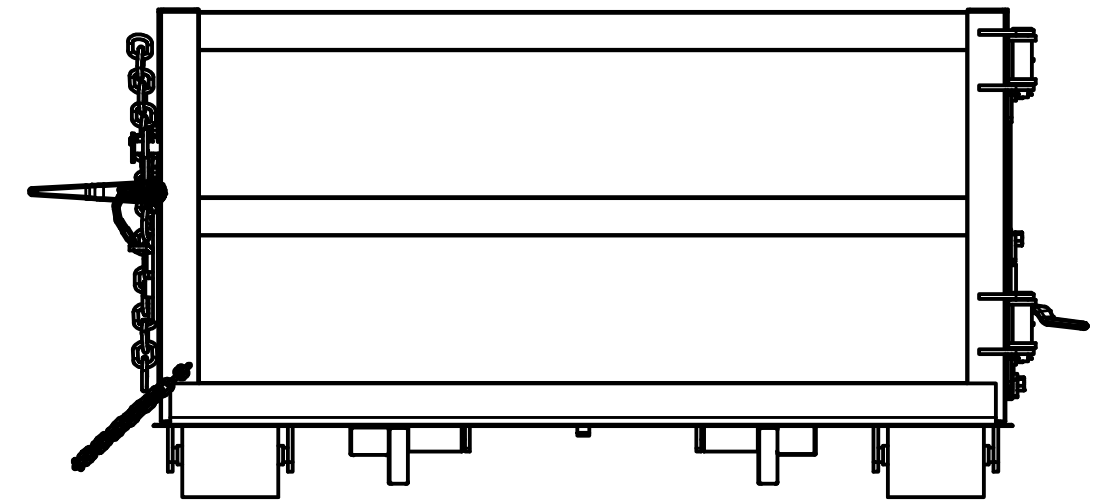
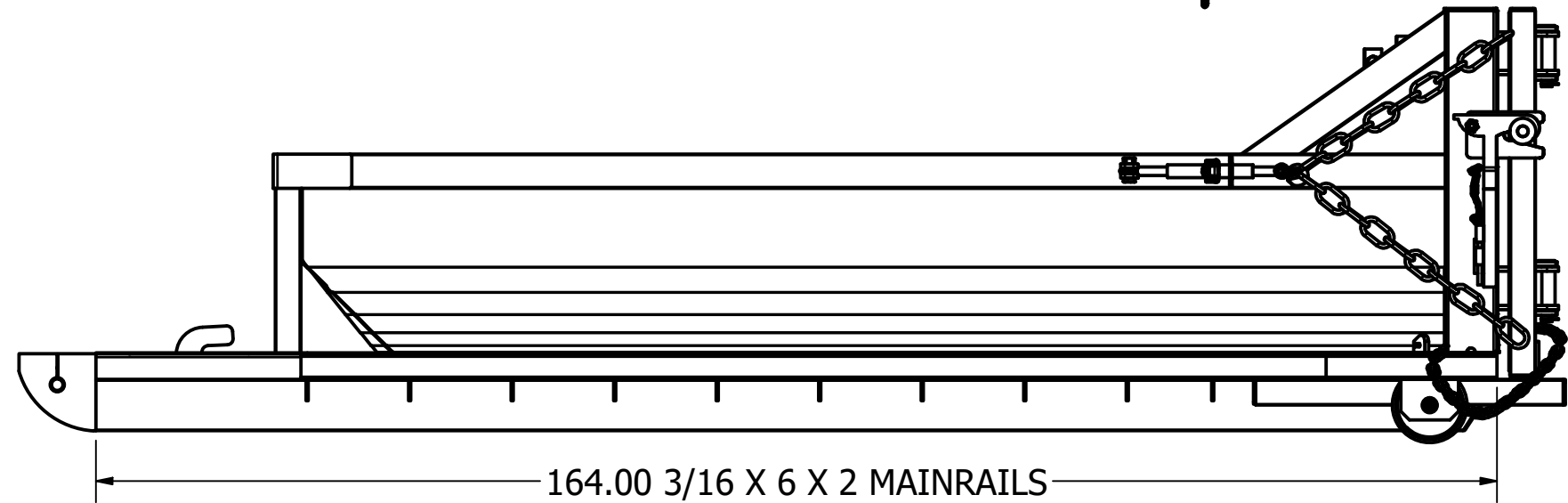
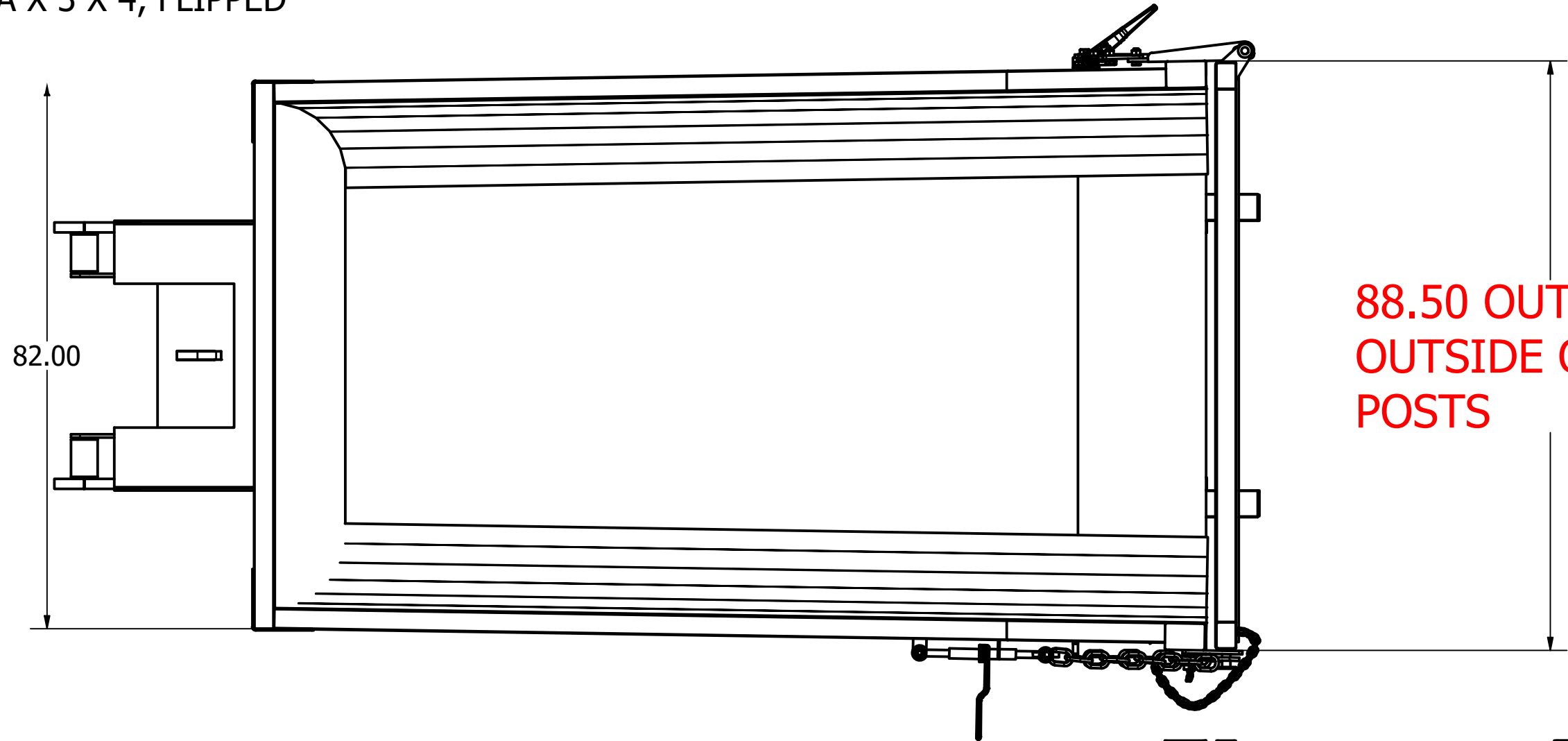

DRAWN	7/10/23	CUSTOM CONTAINER SOLUTIONS		
CELY		TITLE		
CHECKED		5.8CY-14S-24I-TUB-CAB-SGT-SD		
QC		SIZE	DWG NO	REV
MFG		A	CCS STD 5.8CY WASHOUT	
APPROVED		SCALE	SHEET 1 OF 10	

5.8CY-14S-24I-TUB-CAB-SGT-SD

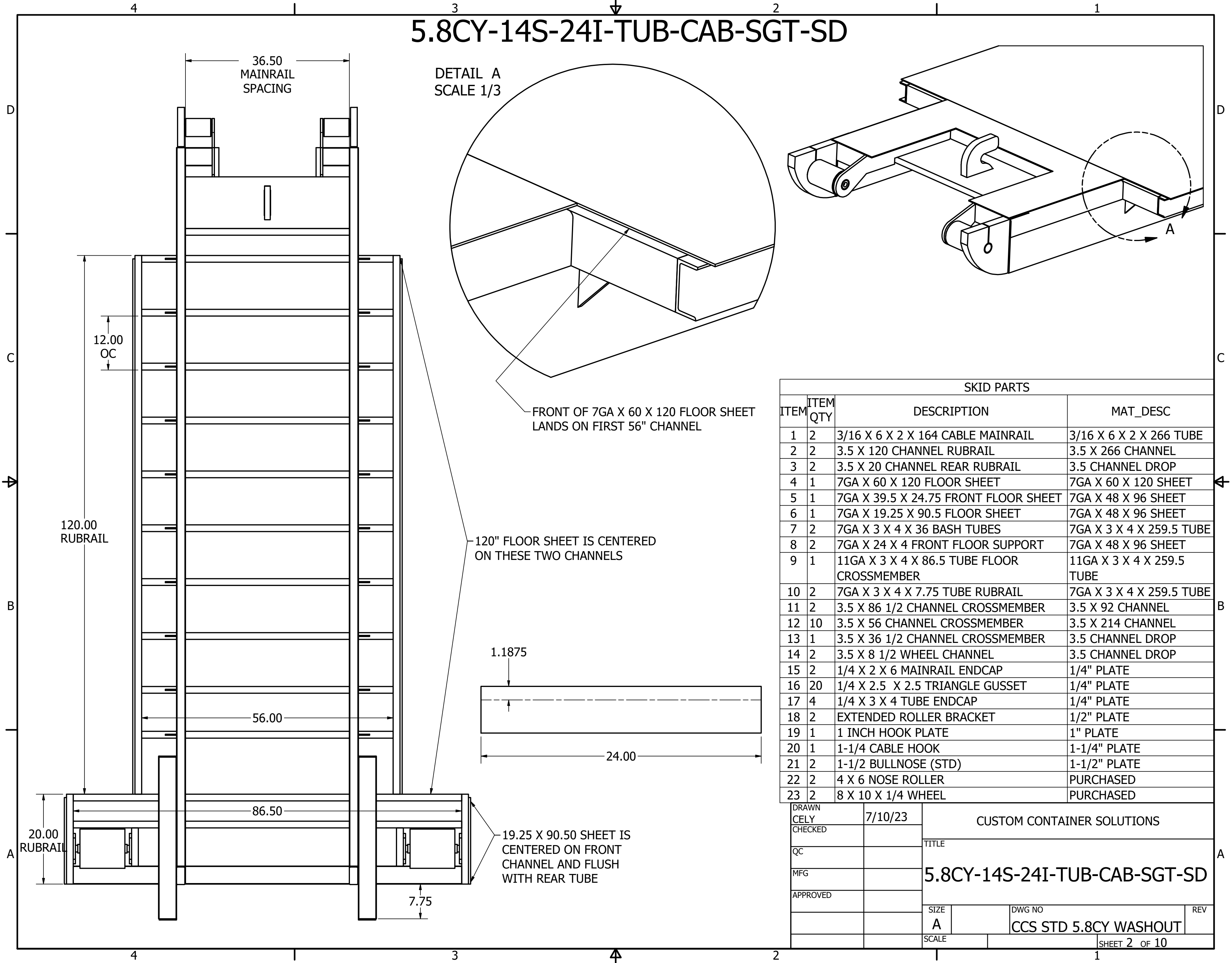

SKID PARTS			
ITEM	ITEM QTY	DESCRIPTION	MAT_DESC
1	2	3/16 X 6 X 2 X 164 CABLE MAINRAIL	3/16 X 6 X 2 X 266 TUBE
2	2	3.5 X 120 CHANNEL RUBRAIL	3.5 X 266 CHANNEL
3	2	3.5 X 20 CHANNEL REAR RUBRAIL	3.5 CHANNEL DROP
4	1	7GA X 60 X 120 FLOOR SHEET	7GA X 60 X 120 SHEET
5	1	7GA X 39.5 X 24.75 FRONT FLOOR SHEET	7GA X 48 X 96 SHEET
6	1	7GA X 19.25 X 90.5 FLOOR SHEET	7GA X 48 X 96 SHEET
7	2	7GA X 3 X 4 X 36 BASH TUBES	7GA X 3 X 4 X 259.5 TUBE
8	2	7GA X 24 X 4 FRONT FLOOR SUPPORT	7GA X 48 X 96 SHEET
9	1	11GA X 3 X 4 X 86.5 TUBE FLOOR CROSSMEMBER	11GA X 3 X 4 X 259.5 TUBE
10	2	7GA X 3 X 4 X 7.75 TUBE RUBRAIL	7GA X 3 X 4 X 259.5 TUBE
11	2	3.5 X 86 1/2 CHANNEL CROSSMEMBER	3.5 X 92 CHANNEL
12	10	3.5 X 56 CHANNEL CROSSMEMBER	3.5 X 214 CHANNEL
13	1	3.5 X 36 1/2 CHANNEL CROSSMEMBER	3.5 CHANNEL DROP
14	2	3.5 X 8 1/2 WHEEL CHANNEL	3.5 CHANNEL DROP
15	2	1/4 X 2 X 6 MAINRAIL ENDCAP	1/4" PLATE
16	20	1/4 X 2.5 X 2.5 TRIANGLE GUSSET	1/4" PLATE
17	4	1/4 X 3 X 4 TUBE ENDCAP	1/4" PLATE
18	2	EXTENDED ROLLER BRACKET	1/2" PLATE
19	1	1 INCH HOOK PLATE	1" PLATE
20	1	1-1/4 CABLE HOOK	1-1/4" PLATE
21	2	1-1/2 BULLNOSE (STD)	1-1/2" PLATE
22	2	4 X 6 NOSE ROLLER	PURCHASED
23	2	8 X 10 X 1/4 WHEEL	PURCHASED

DRAWN	7/10/23	CUSTOM CONTAINER SOLUTIONS	
CHECKED		TITLE	
QC		5.8CY-14S-24I-TUB-CAB-SGT-SD	
MFG		SIZE	DWG NO
APPROVED		A	CCS STD 5.8CY WASHOUT
		SCALE	REV
			SHEET 2 OF 10

5.8CY-14S-24I-TUB-CAB-SGT-SD

NOTE:
1. TOP RAIL IS FACING 4" SIDE OUT
NOT THE STANDARD WAY

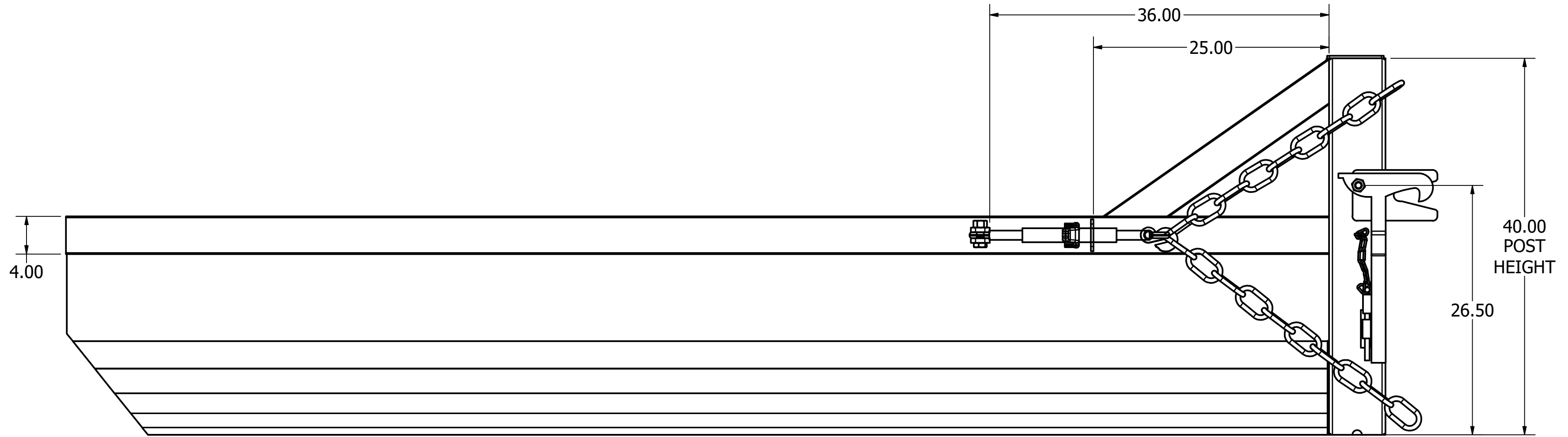

4" DEEP POSTS

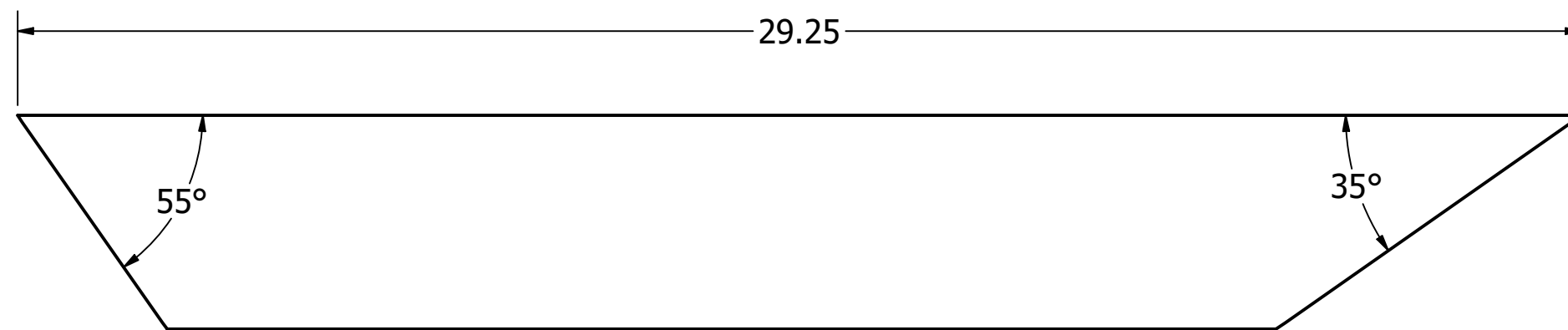
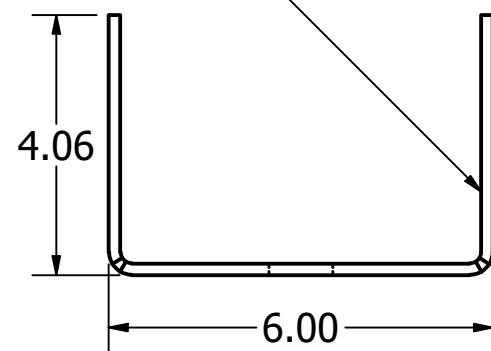

DRIVER SIDE WALL ASSEMBLY			
ITEM	ITEM QTY	DESCRIPTION	MAT_DESC
1	1	11GA X 3 X 4 X 134 WALL TOPRAIL	11GA X 3 X 4 X 259.5 TUBE
2	1	11GA X 3 X 4 X 29.25 ANGLED TOPRAIL TUBE	11GA X 3 X 4 X 259.5 TUBE
3	1	12GA X 29.75 X 140 - 6 BEND WALL SHEET	12GA X 60 X 144 SHEET
4	1	7GA X 13.5 X 40 WALL POST BENT 3.906"	7GA X 48 X 96 SHEET
5	1	0.50 X 9 LATCH LOCK PIN	1/2" x 20 ROUND BAR
6	1	0.5 X 1 X 4 FLAT LATCH MOUNT	1/2 X 1 X 240 FLAT BAR
7	2	2 X 0.75 LATCH LOCK PIPE	3/4 X 240 PIPE
8	19	1/2" BINDER CHAIN	1/2" GRADE 70 CHAIN
9	1	7 X .1875 LATCH LOCK CHAIN	3/16 GRADE 30 CHAIN
10	1	12GA X 31.8125 X 18.25 TRIANGLE WALL SHEET	12GA SHEET (CUT ON PLASMA)
11	1	10GA X 10 X 11 FRONT OF POST GUSSET	10GA SHEET
12	1	10GA X 10 X 10 REAR OF POST GUSSET	10GA SHEET
13	1	1/4 X 4 X 6 ENDCAP	1/4" PLATE
14	1	BINDER GUSSET WASHOUT 1/4	1/4" PLATE
15	1	FLIP CATCH WITH HANDLE 0.50	1/2" PLATE
16	2	1/2 TYP BINDER BRACKET	1/2" PLATE
17	1	1/2 STANDARD GUIDE PLATE	1/2" PLATE
18	1	3/8 RATCHET BINDER 5400 -GRADE 70	PURCHASED
19	2	3/4 LOCK NUT	PURCHASED
20	2	3/4-10 X 2 HEX GR5 BOLT	PURCHASED

DRAWN	7/10/23	CUSTOM CONTAINER SOLUTIONS	
CELY		TITLE	
CHECKED		5.8CY-14S-24I-TUB-CAB-SGT-SD	
QC		SIZE	DWG NO
MFG		A	CCS STD 5.8CY WASHOUT
APPROVED		SCALE	REV
			SHEET 3 OF 10

5.8CY-14S-24I-TUB-CAB-SGT-SD

NOTE:
1. TOP RAIL IS FACING 4" SIDE OUT
NOT THE STANDARD WAY

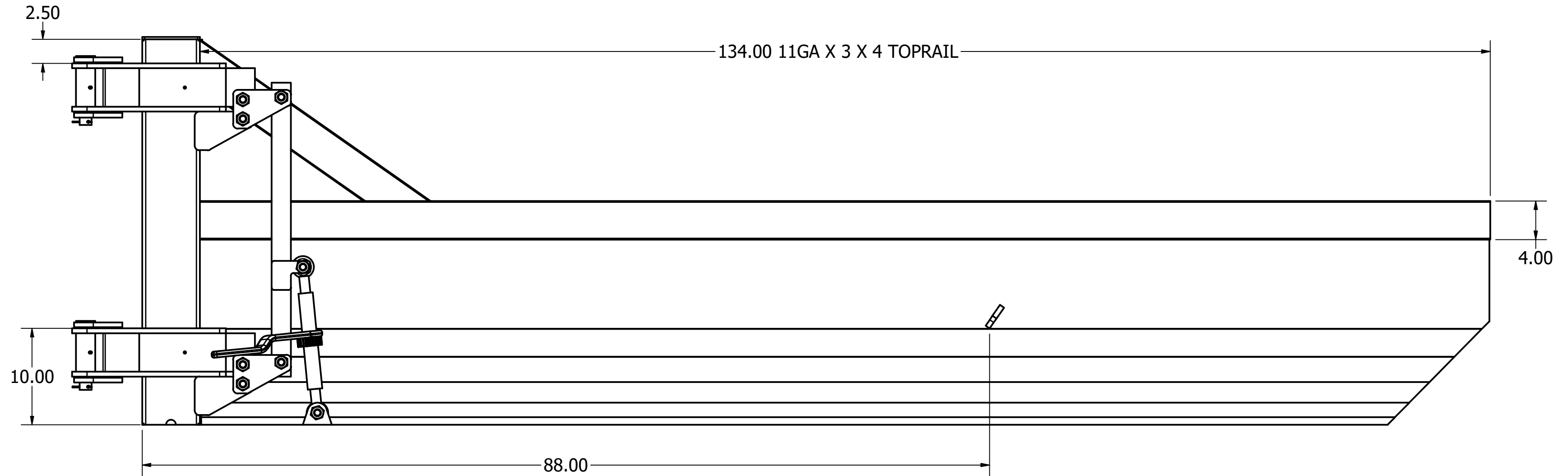

4" DEEP POSTS

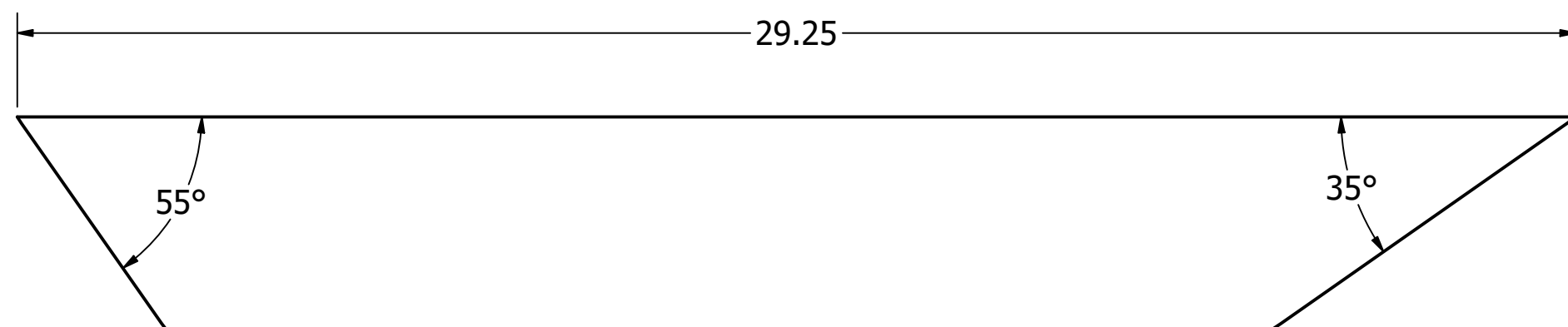
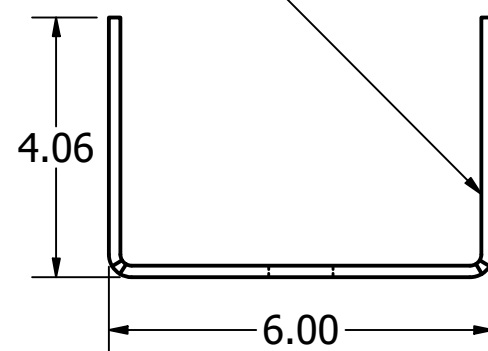

PASSENGER SIDE WALL PARTS			
ITEM	ITEM QTY	DESCRIPTION	MAT_DESC
1	1	11GA X 3 X 4 X 134 WALL TOPRAIL	11GA X 3 X 4 X 259.5 TUBE
2	1	11GA X 3 X 4 X 29.25 ANGLED TOPRAIL TUBE	11GA X 3 X 4 X 259.5 TUBE
3	1	12GA X 29.75 X 140 - 6 BEND WALL SHEET	12GA X 60 X 144 SHEET
5	1	7GA X 13.5 X 40 HINGE POST BENT 3.906"	7GA X 48 X 96 SHEET
6	1	0.375 X 2 X 30.5 FLAT LATCH LINKAGE	3/8 X 2 X 240 FLATBAR
4	1	12GA X 31.8125 X 18.25 TRIANGLE WALL SHEET	12GA SHEET (CUT ON PLASMA)
7	1	10GA X 10 X 11 FRONT OF POST GUSSET	10GA SHEET
8	1	10GA X 10 X 10 REAR OF POST GUSSET	10GA SHEET
9	1	1/4 X 4 X 6 ENDCAP	1/4" PLATE
10	1	1/2 SAFETY CHAIN HOOK	1/2" PLATE
11	2	LATCH LINKAGE STATIONARY PIECE	1/2" PLATE
12	2	LATCH LINKAGE PIVOT PIECE	1/2" PLATE
13	2	LATCH ELBOW	1/2" PLATE
14	2	CH BINDER BRACKET 1/2	1/2" PLATE
15	1	3/8 RATCHET BINDER 5400 - GRADE 70	PURCHASED
16	8	3/4-10 HEX NUT GR5 PLATED	PURCHASED
17	8	3/4-10 X 2 BOLT GR5 PLATED	PURCHASED
18	2	MECHANICAL HINGE	PURCHASED

DRAWN	CELY	7/10/23	CUSTOM CONTAINER SOLUTIONS	
CHECKED			TITLE	
QC			5.8CY-14S-24I-TUB-CAB-SGT-SD	
MFG			SIZE	DWG NO
APPROVED			A	CCS STD 5.8CY WASHOUT
			SCALE	REV
				SHEET 4 OF 10

5.8CY-14S-24I-TUB-CAB-SGT-SD

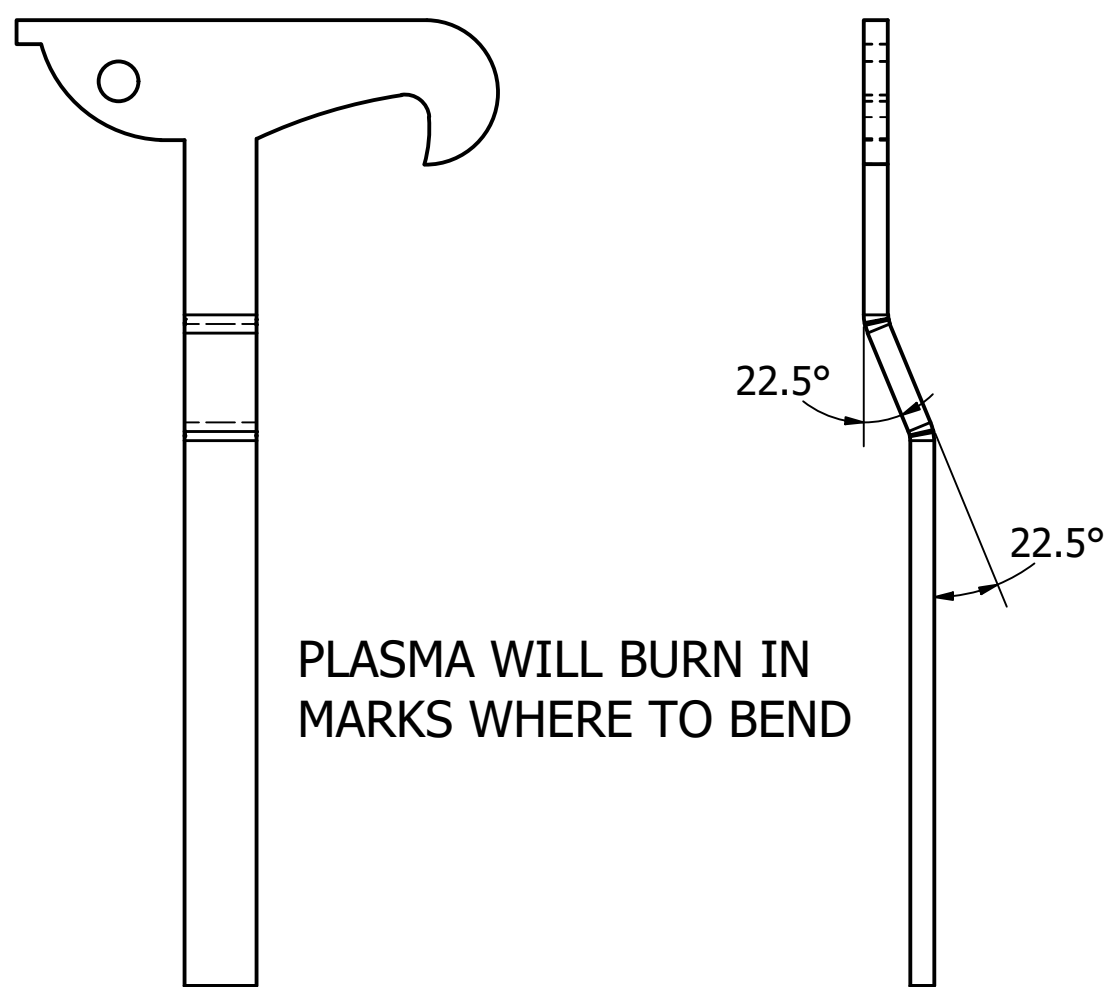
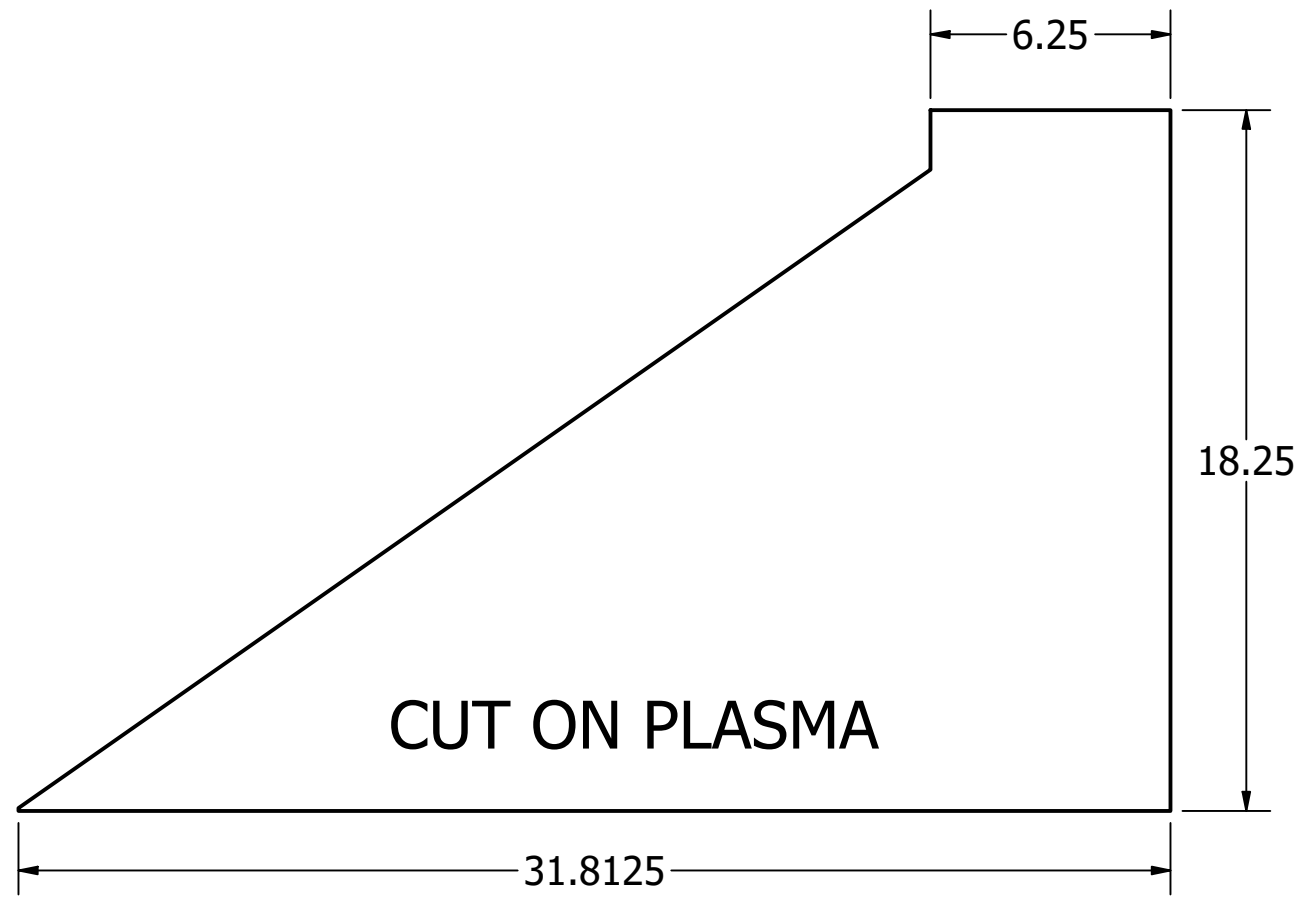
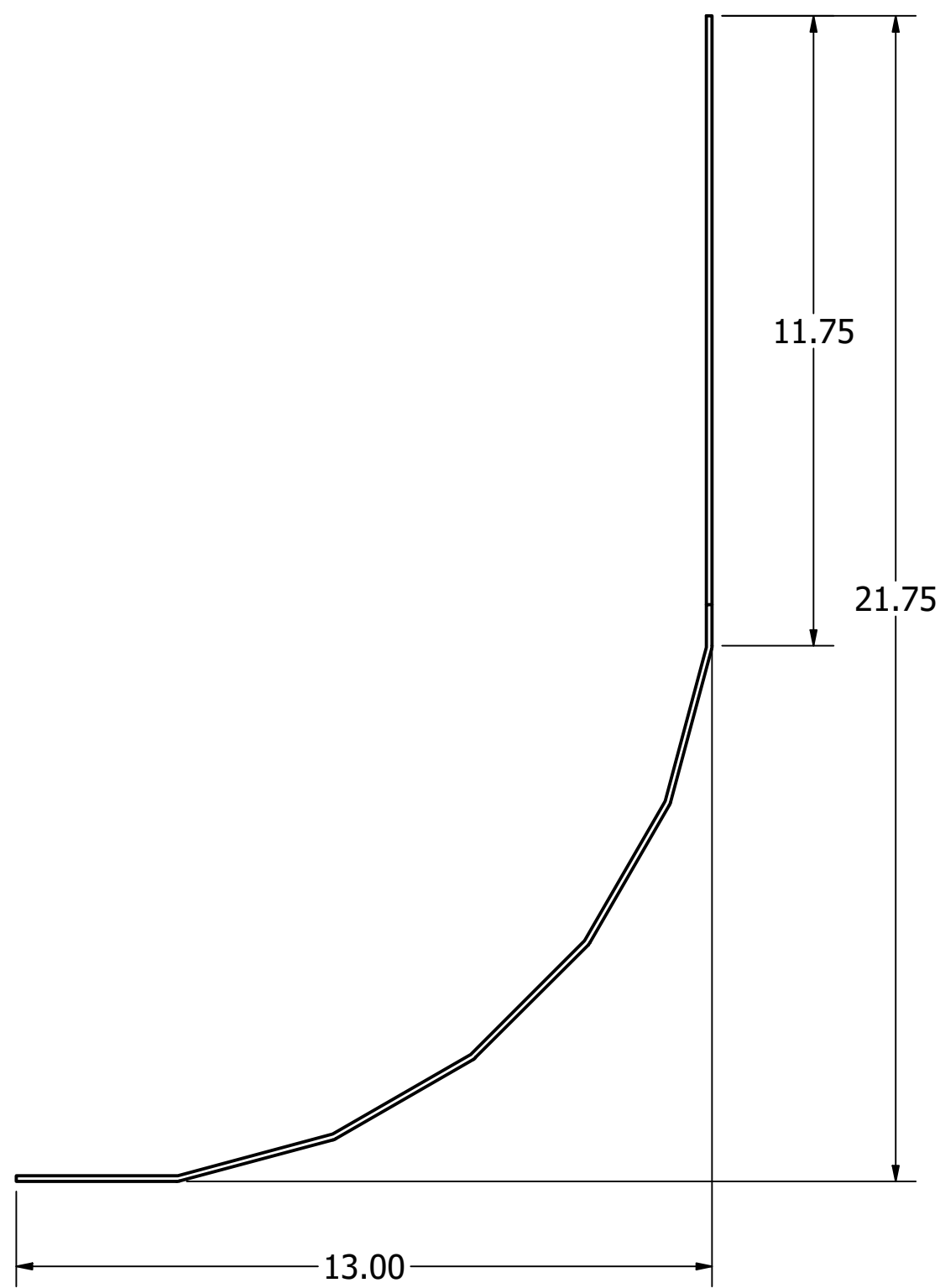
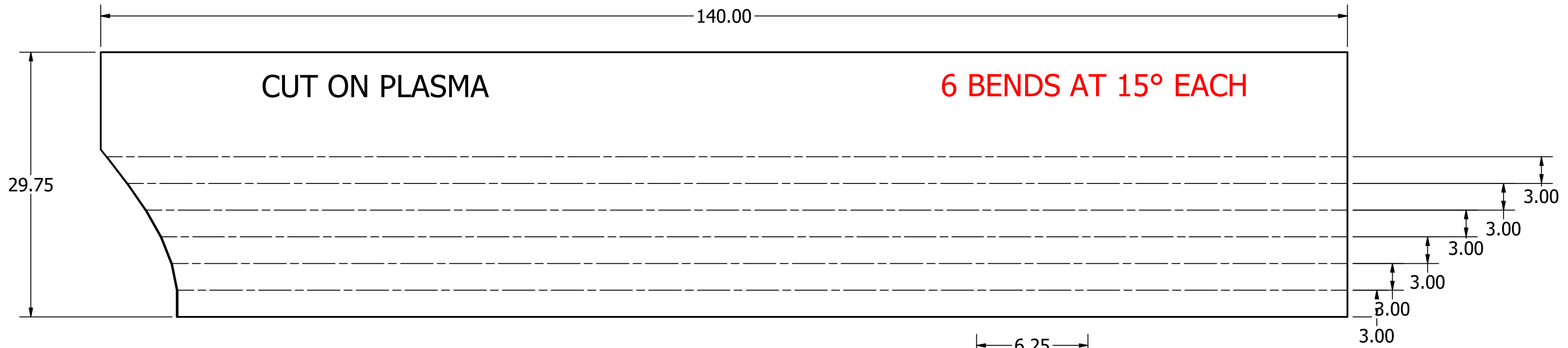

DRAWN	7/10/23	CUSTOM CONTAINER SOLUTIONS		
CELY		TITLE		
CHECKED		5.8CY-14S-24I-TUB-CAB-SGT-SD		
QC		SIZE	DWG NO	REV
MFG		A	CCS STD 5.8CY WASHOUT	
APPROVED		SCALE	SHEET 5 OF 10	

NOTES:
 1. FRONT TOP RAIL IS FACING WITH THE 4" SIDE FACING OUT

5.8CY-14S-24I-TUB-CAB-SGT-SD

DOOR ASSEMBLY			
ITEM	ITEM QTY	DESCRIPTION	MAT_DESC
1	2	11GA X 3 X 4 X 42.625 DOOR UPRIGHT TUBE	11GA X 3 X 4 X 259.5 TUBE
2	3	11GA X 3 X 4 X 80 DOOR HORIZONTAL TUBE	11GA X 3 X 4 X 259.5 TUBE
3	1	12GA X 42.5 X 87.5 DOOR SHEET	12GA X 48 X 88.50 SHEET
4	1	STD DOOR PIN ASSEMBLY	SUB ASSEMBLY
12.1	1	1/4 X 3 DOOR STRIKER PIN WASHER	PURCHASED
12.2	1	1.25 X 3.25 DOOR PIN ROUND BAR	1-1/4 X 240 ROUND BAR
5	2	1/4 X 3 X 4 TUBE ENDCAP	1/4" PLATE
6	4	12GA X 37 LONG X 1.5 WIDE BENT DOOR TRACK	12GA SHEET DROP
7	2	12GA X 80.5 LONG X 1.5 WIDE BENT DOOR TRACK	12GA SHEET DROP
8	1	T-SEAL 166.6875 INCHES	PURCHASED
9	1	3/8 X 7 X 86 BRACE	3/8" PLATE

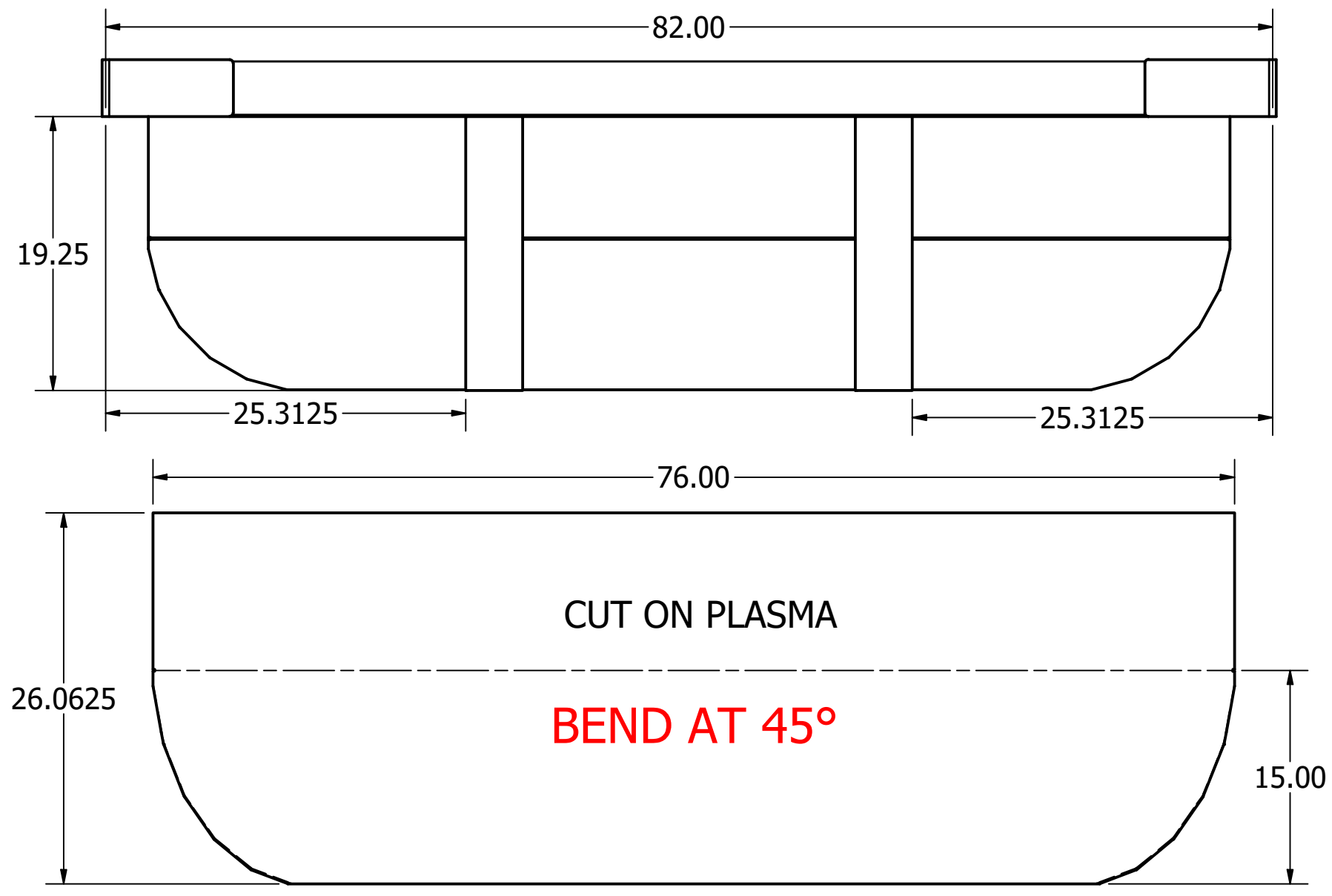
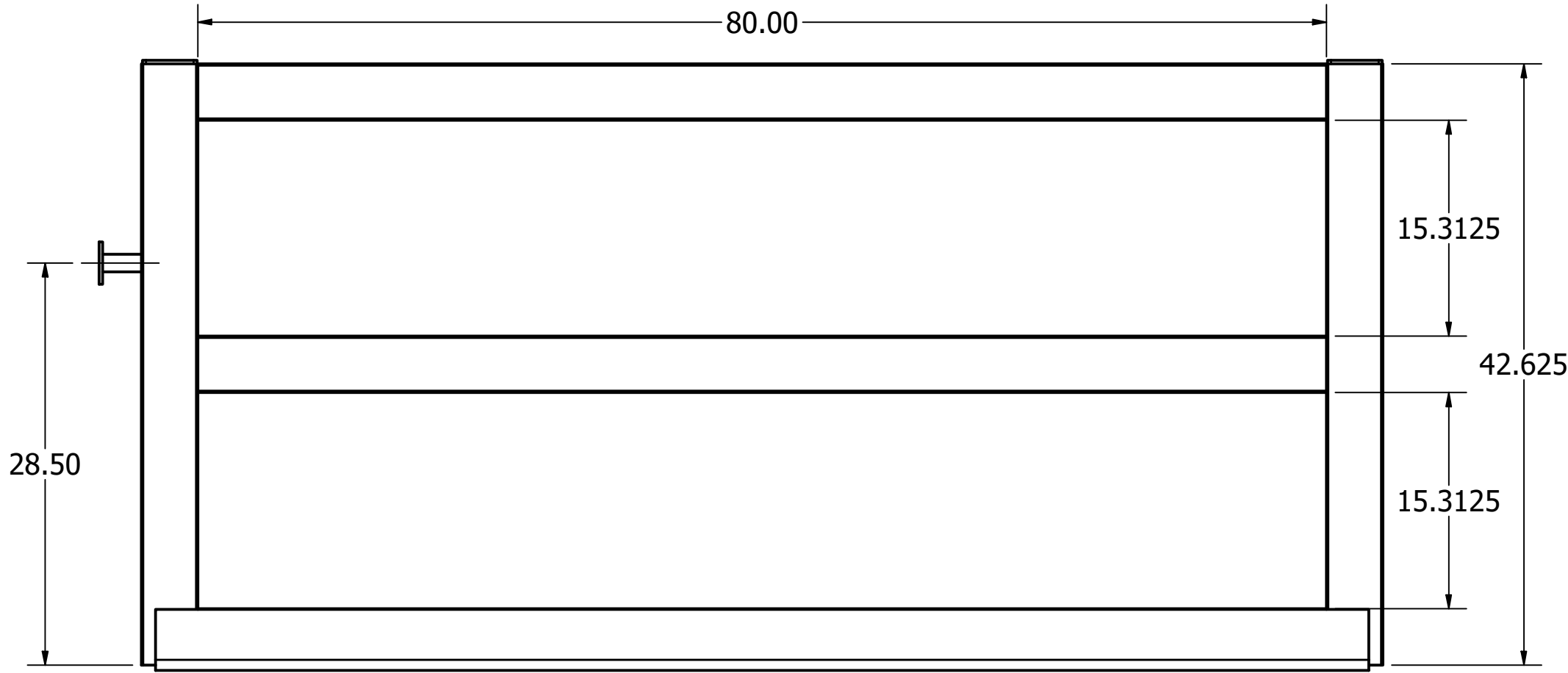

FRONT WALL ASSEMBLY			
ITEM	ITEM QTY	DESCRIPTION	MAT_DESC
1	1	11GA X 3 X 4 X 82 FRONT TOPRAIL TUBE	11GA X 3 X 4 X 259.5 TUBE
2	1	12GA X 26.0625 X 76 FRONT SHEET	12GA X 60 X 88.25 SHEET
3	2	11GA X 3 X 4 X 19.25 FRONT UPRIGHT TUBE	11GA X 3 X 4 X 259.5 TUBE
4	2	CORNER WRAP ENDCAP 7GA X 4 X 18	7GA SHEET

DRAWN	7/10/23	CUSTOM CONTAINER SOLUTIONS	
CELY		TITLE	
CHECKED		5.8CY-14S-24I-TUB-CAB-SGT-SD	
QC		SIZE	DWG NO
MFG		A	CCS STD 5.8CY WASHOUT
APPROVED		SCALE	REV
			SHEET 6 OF 10

5.8CY-14S-24I-TUB-CAB-SGT-SD



T-SEAL COMPONENTS			
ITEM	ITEM QTY	DESCRIPTION	MAT_DESC
1	4	12GA X 37 LONG X 1.5 WIDE BENT DOOR TRACK	12GA SHEET DROP
2	2	12GA X 80.5 LONG X 1.5 WIDE BENT DOOR TRACK	12GA SHEET DROP
3	1	T-SEAL 166.6875 INCHES	PURCHASED

DRAWN	7/10/23
CELY	
CHECKED	
QC	
MFG	
APPROVED	

CUSTOM CONTAINER SOLUTIONS			
TITLE			
5.8CY-14S-24I-TUB-CAB-SGT-SD			
SIZE		DWG NO	REV
A		CCS STD 5.8CY WASHOUT	
SCALE		SHEET 7 OF 10	